

Skillment



Environmental Studies

WORKBOOK



PMP Planet[®]
Multimedia Publishers
The Ultimate Resource

PM PUBLISHERS PVT. LTD.

Skillment Environmental Studies Workbook – FS 4 (Class – 1)

PMP Editorial Team

© 2022 by PM Publishers Pvt. Ltd.

All rights reserved. No part of this publication may be reproduced, stored in a retrieval system, transmitted or utilised in any form or by any means, electronic or mechanical, including photocopying, recording or otherwise, without the prior written permission of the publisher, or as expressed by law, or under terms agreed with the appropriate Reprographics Rights Organization(s).

This book is sold subject to the condition that it shall not, by way of trade or otherwise, be lent, resold, hired out, or otherwise circulated in any form of binding or cover other than that in which it is published, without the prior written permission of its copyright holder.

ISBN : 978-93-94820-63-0

First Edition : 2023

Price : ₹ 182/-

Printed at :

Published in India by :



PM PUBLISHERS PVT. LTD.

C-55, Sector-65, NOIDA, Gautam Budh Nagar, -201 301 (U.P.), India

Ph.: 0120-4300130-33, Mob.: 9540990177

E-mail: info@pmpublishers.in

URL: www.pmpublishers.in

Preface

With a vision of making quality education accessible to all from the Foundational Stage to Secondary Stage of schooling, the **National Education Policy (NEP) 2020** has issued a new pedagogical and academic structure. The new pedagogical and academic structure has been divided into four stages as mentioned below:

Foundational Stage (5 years): Nursery, LKG, UKG, Std. 1 and Std. 2	(3-8 years)
Preparatory Stage (3 years): Std. 3, Std. 4 and Std. 5	(8-11 years)
Middle Stage (3 years): Std. 6, Std.7 and Std. 8	(11-14 years)
Secondary Stage (4 years): Std. 9, Std. 10, Std. 11 and Std. 12	(14-18 years)

In the new 5+3+3+4 structure, a strong base of Early Childhood Care and Education (ECCE) from age 3 is also included. The overall aim of Early Childhood Care and Education (ECCE) is to attain optimal outcomes in the following domains:

- ✓ Physical and motor development
- ✓ Cognitive development
- ✓ Social-emotional-ethical development
- ✓ Cultural/Artistic development
- ✓ Development of communication and early language, literacy, and numeracy

Our new series, **Skillment**, is properly graded and contains age-appropriate course material for the learners of Foundational Stage to achieve the aims and objectives outlined in the **National Curriculum Framework (NCF) for Foundational Stage 2022**. The series covers different subjects which are classified under the following categories:

FS 1 (3+ years): Maths, English, EVS, Hindi, Art and Craft, Kavitayen aur Kahaniyan, Rhymes and Stories

FS 2 (4+ years): Maths, English, EVS, Hindi, Art and Craft, Kavitayen aur Kahaniyan, Rhymes and Stories

FS 3 (5+ years): Maths, English, EVS, Hindi, Art and Craft, Kavitayen aur Kahaniyan, Rhymes and Stories

FS 4 (6+ years): Maths, English, EVS, Hindi, English Grammar, Art and Craft, Computer and GK

FS 5 (7+ years): Maths, English, EVS, Hindi, English Grammar, Art and Craft, Computer and GK

Apart from the main books, we are also providing **Workbooks** with Maths, English, EVS and Hindi to learners for extra practice.

The whole set of books for each class also carries a **Teacher's Resource Kit** which contains various kinds of relevant and interesting teaching aid that teachers may use in the classroom.

A **booklet on Social and Emotional Learning (SEL)** including lesson plans is provided for the teachers to inculcate SEL skills in the learners.

Skillment App is for skill building and joyful teaching and learning for teachers and learners.

Web Support

Our web portal pmponline.co.in provides a vital web support to teachers and learners. It includes the following:

- **Multimedia ebooks:** consist of animation, audio, video, and interactive exercises
- **Additional worksheets:** printable worksheets for extra practice
- **Teacher's resource:** comprises lesson plans
- **Virtual lessons:** consist of pre-recorded video lessons
- **AR (Augmented Reality) App both for android and iOS:** turns books into smart books with better visualisation and concept clarity

It is a concerted attempt to make the series more useful for the teachers, parents and kids. We hope this series will be quite helpful in achieving the goals set by the NEP 2020. However, we shall appreciate valuable and constructive feedback from teachers and parents to improve the books with every new edition.

—Publishers



Contents

S.No.	Chapter Name	Page No.
1.	About Myself	5
2.	My Body	7
3.	Healthy Habits	8
4.	My Family	10
5.	We Need Food	12
6.	We Need Clothes	13
7.	We Need a House	15
8.	Air and Water	16
9.	Plants Around Us	18
10.	Animals Around Us	19
11.	Homes of Animals	20
12.	Our School	21
13.	Places Around Us	23
14.	Our Helpers	25
15.	Travel	26
16.	The Earth and the Sky	28
17.	Our Festivals	30
18.	Our Safety	32



About Myself



1. Paste your photograph in the given box and fill in the details.

- Name: _____
- Class: _____
- Section: _____
- School: _____
- Father's Name: _____
- Mother's Name: _____
- Contact No.: _____
- Home Address: _____



2. What is your date of birth? Write it here in the box:

Also, find out and write your age:

Count the candles given below. Cross out (x) as many candles as are not required for your birthday cake.

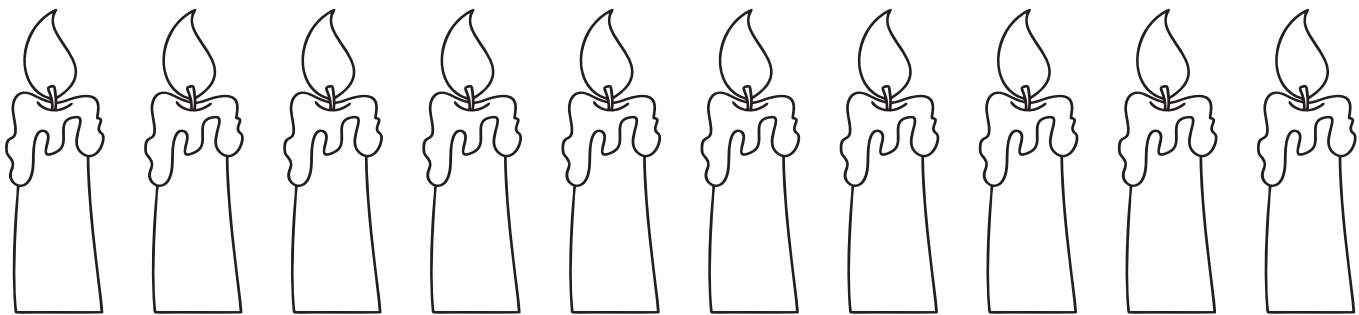

Now, write the number of candles left:

3. Write the name of your favourite colour. Colour the balloon with it.

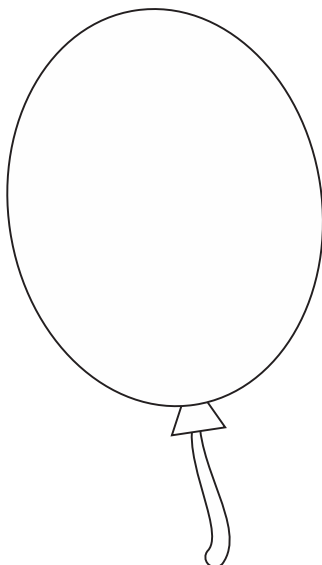

Name of colour:

4. Answer the following questions.

a. Write the names of the following:

- Favourite fruit: _____
- Favourite vegetable: _____
- Favourite sport: _____
- Favourite dish: _____

b. Write two activities you like to do at school.

c. Talk to two of your friends to complete this table.

Name	Surname	Nickname
● _____ _____	_____	_____
● _____ _____	_____	_____



1. Identify the body parts and write their names.

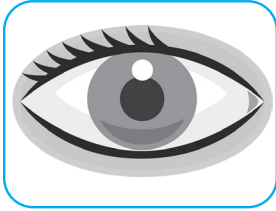

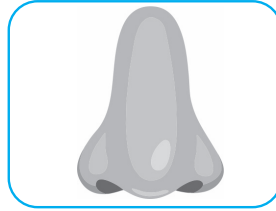



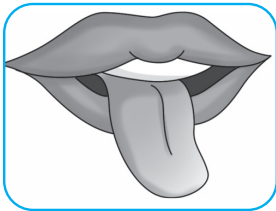

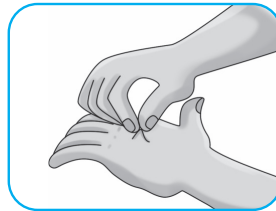

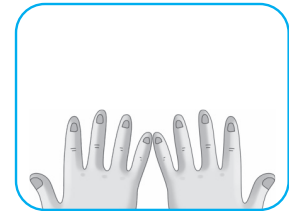

2. Match the pictures with their functions correctly.



•



•



•



•

• To lift objects

• To see objects

• To hear sounds

• To sense smell



Healthy Habits



1. How often and when do you do the following activities? Tick (✓) the options that are true about you. You can tick more than one option if needed.

Brushing of teeth	:	Daily	<input type="checkbox"/>	Weekly	<input type="checkbox"/>	Monthly	<input type="checkbox"/>
Bathing	:	Daily	<input type="checkbox"/>	Weekly	<input type="checkbox"/>	Monthly	<input type="checkbox"/>
Trimming of nails	:	Daily	<input type="checkbox"/>	Weekly	<input type="checkbox"/>	Monthly	<input type="checkbox"/>
Washing of hands	:	Before using the toilet	<input type="checkbox"/>				
		After using the toilet	<input type="checkbox"/>				
		Before eating meals	<input type="checkbox"/>				

2. Tick (✓) the healthy food items and cross out (×) those which are not healthy.

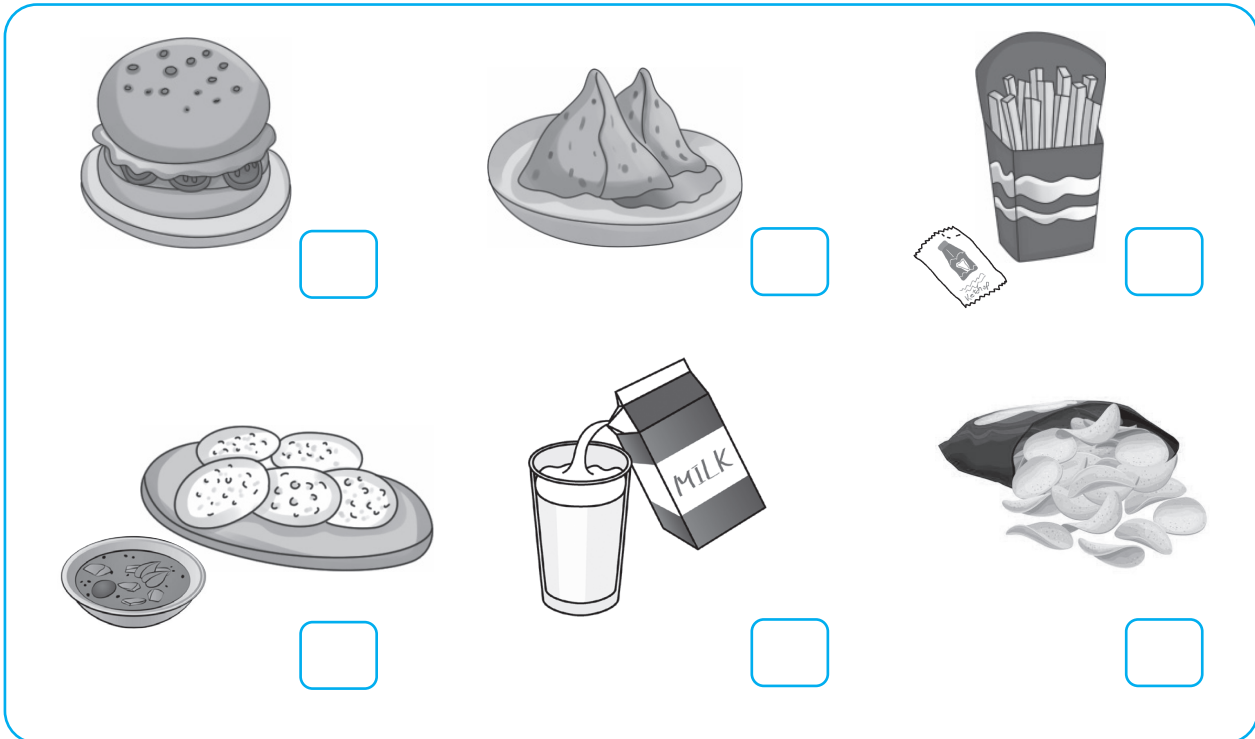

3. We should drink plenty of water daily. Tick (✓) the option which is good for the environment.



4. Answer the following questions.

a. Why can we not see germs around us?

b. Write one cleanliness habit that we should follow.

c. Name some healthy food items.

d. Why should we do physical exercise?

e. What does a sound sleep give us?



1. Colour the circle green for small family and blue for the large one.

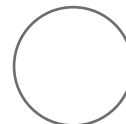
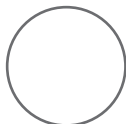

2. Tick (✓) the correct option.

- What do you call your parent's father?

a. Grandfather <input type="checkbox"/>	b. Granduncle <input type="checkbox"/>	c. Uncle <input type="checkbox"/>
---	--	-----------------------------------
- What do you call your parent's mother?

a. Grandmother <input type="checkbox"/>	b. Grand aunt <input type="checkbox"/>	c. Aunt <input type="checkbox"/>
---	--	----------------------------------
- What do you call your parent's brother?

a. Cousin <input type="checkbox"/>	b. Friend <input type="checkbox"/>	c. Uncle <input type="checkbox"/>
------------------------------------	------------------------------------	-----------------------------------
- What do you call your parent's sister?

a. Niece <input type="checkbox"/>	b. Aunt <input type="checkbox"/>	c. Cousin <input type="checkbox"/>
-----------------------------------	----------------------------------	------------------------------------
- What do you call your uncle's wife?

a. Cousin <input type="checkbox"/>	b. Mother <input type="checkbox"/>	c. Aunt <input type="checkbox"/>
------------------------------------	------------------------------------	----------------------------------

3. Write the names of the following family members to make a family tree.

a. Write the names of your grandparents.

b. Write the names of your parents, uncles and aunts.

c. Write the names of yourself, your siblings and your cousins.

4. Colour the picture.





We Need Food



1. Match the times of day with the meals.

Morning

Lunch

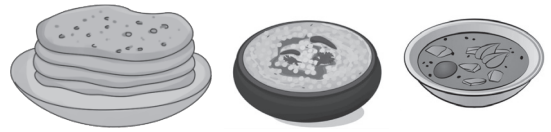

Afternoon

Breakfast



Night

Dinner



2. Write P against the food items that come from plants. Write A against those that come from animals.

Pumpkin

Honey

Milk

Banana

Egg

Grapes

3. Answer the following questions.

a. Why do we eat food? Give two reasons.

b. Name some items we make from milk.

c. What do non-vegetarians eat?



We Need Clothes



1. Identify the clothes and write their names in the given boxes.



2. Answer the following questions.

a. Name some clothes we wear in summer season.

b. What type of clothes do we wear in winter season?

c. From where do we get these clothing materials?

- Cotton _____
- Silk _____
- Wool _____

3. Tick (✓) the correct option.

- Where does cotton come from?
a. Animals b. Plants c. Insects
- Which fibre do sheep give us?
a. Silk b. Cotton c. Wool
- Which of the following gives us silk fibre?
a. Silkworm b. Ant c. Cockroach
- In which season do we use an umbrella and gumboots?
a. Winter b. Summer c. Rainy
- Where do you not wear a uniform?
a. At school b. At home c. Neither of these

4. Join the dots to complete the drawing of a frock. Also, colour it as you like.

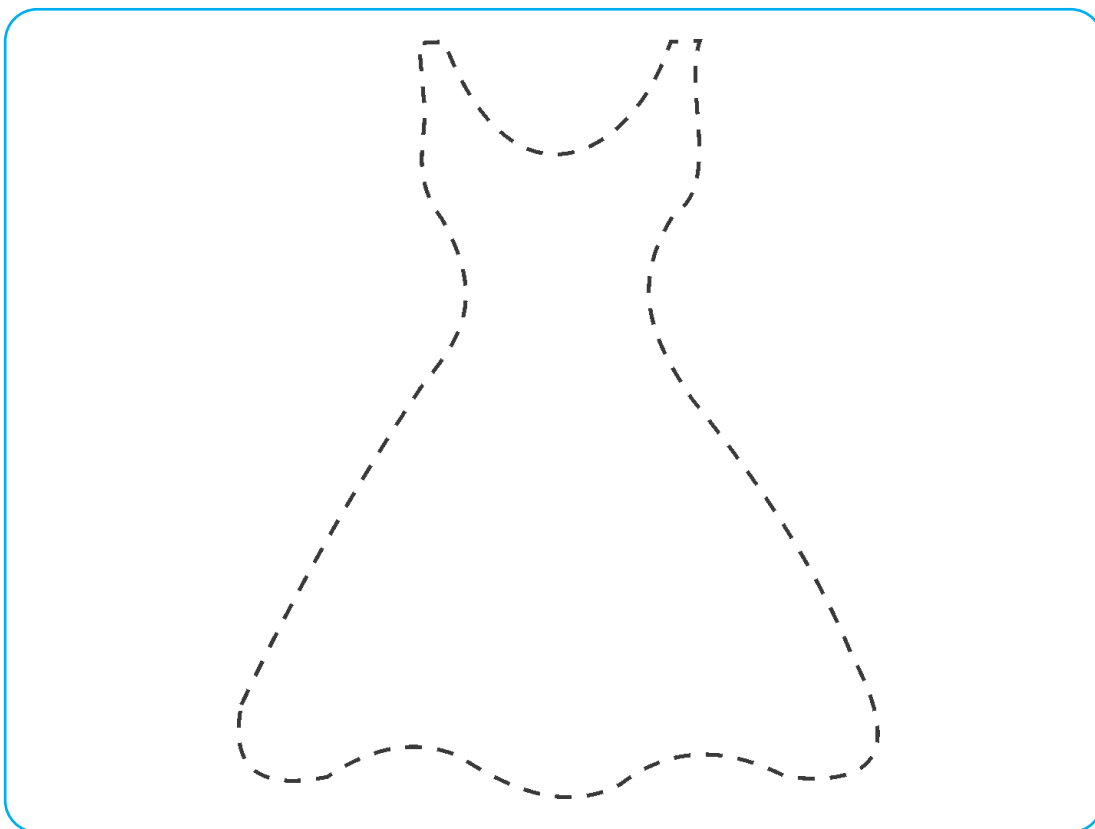



We Need a House



1. Circle the materials which are not used to make kutcha houses.

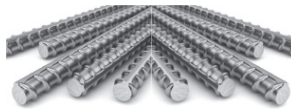
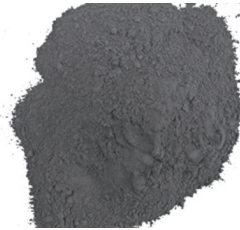
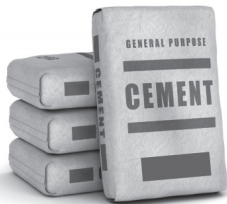

2. Look at the pictures and write the correct words in the boxes.

Kitchen

Dining room

Bedroom

Drawing room



.....

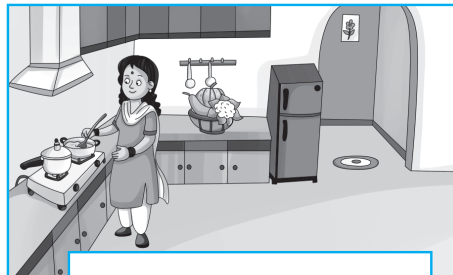

.....

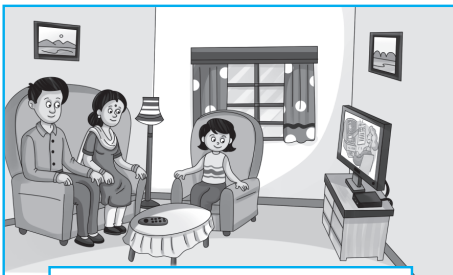

.....



.....



Air and Water



1. Tick (✓) the correct statements and cross out (×) the incorrect ones.

- Air is present all around us.
- We can see air.
- We can feel air.
- Animals need water but plants do not.
- Rainfall is the main source of water.

2. Pick the names of sources of water from the box and write them under the pictures.

River Well Rain Pond

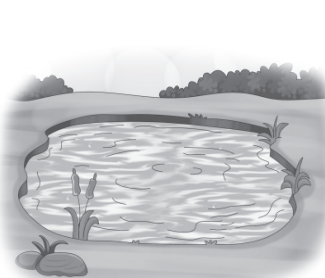
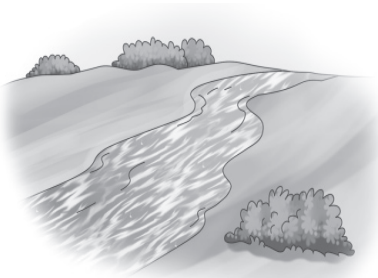

3. Write A for the things or activities that involve the use of air. Write W for those which involve the use of water.



4. Find and mark five sources of water in the word grid. Also write them in the given spaces.

D	L	B	F	T	X	V	K
H	A	N	D	P	U	M	P
K	K	S	G	M	S	B	N
S	E	A	K	L	W	C	E
V	C	R	I	V	E	R	H
R	T	W	M	P	L	J	M
S	M	Z	R	T	L	N	L

(a) _____ (b) _____ (c) _____

(d) _____ (e) _____

5. Answer the following questions.

a. What do you mean by wind?

b. How do streams and rivers form?

c. How do we take out underground water?

d. Write three properties of pure water.



Plants Around Us



1. Cross the odd one in each of the following.

- Banyan Neem Spinach Peepal
- Cotton Mango Lemon Rose
- Mint Spinach Coriander Grapevine
- Pumpkin Gourd Guava Watermelon
- Pea Banyan Grapevine Moneyplant

2. Identify the things we get from plants and write their names from the box.

Cotton Cloves Paper Oil Coffee Nuts















1. Circle the odd picture in each of the following.

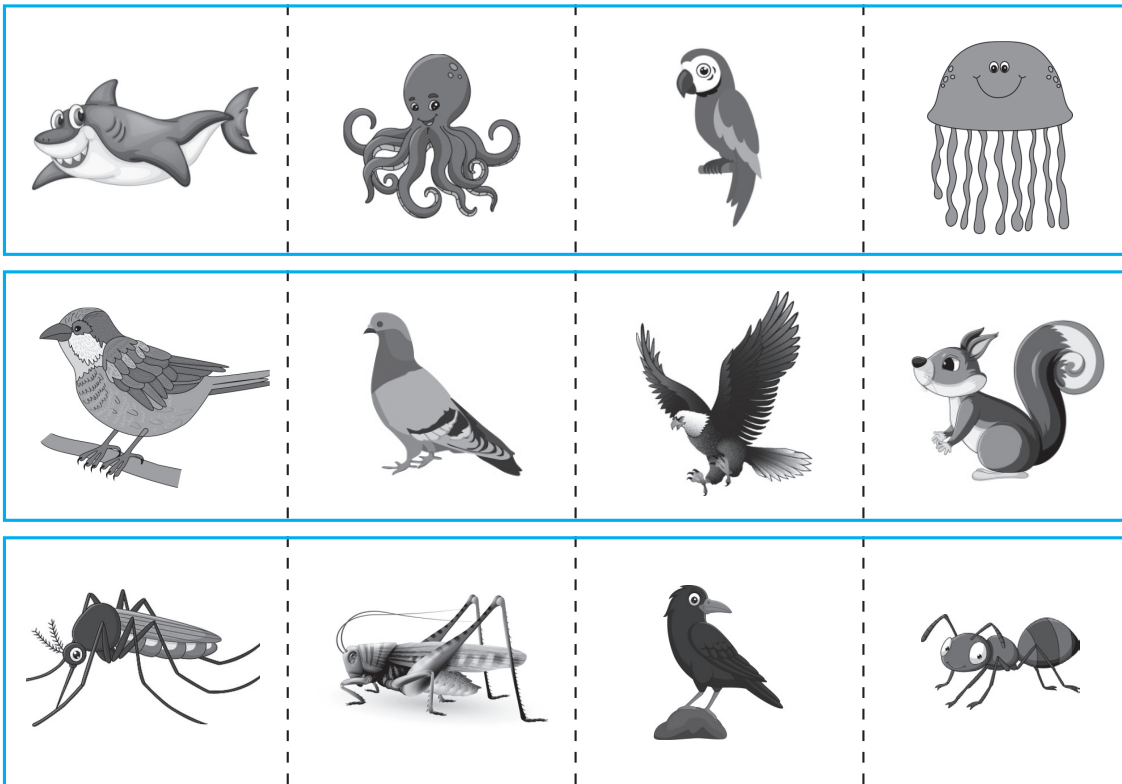

2. Answer the following questions.

a. What are pets?

b. Write the names of some wild animals.

c. What are amphibians?

d. What are insects?



11

Homes of Animals



1. Identify the animals and read their statements. Tick (✓) YES if the statement is true and NO if it is false.



I live in a tree.

YES

NO



I live in a den.

YES

NO

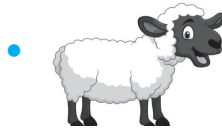

I live in a pen.

YES

NO

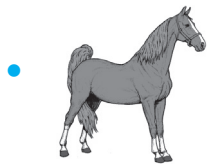

I live in a kennel.

YES

NO



I live in a shed.

YES

NO

2. The hen has lost the way.
Draw a line to show it the way to its home.

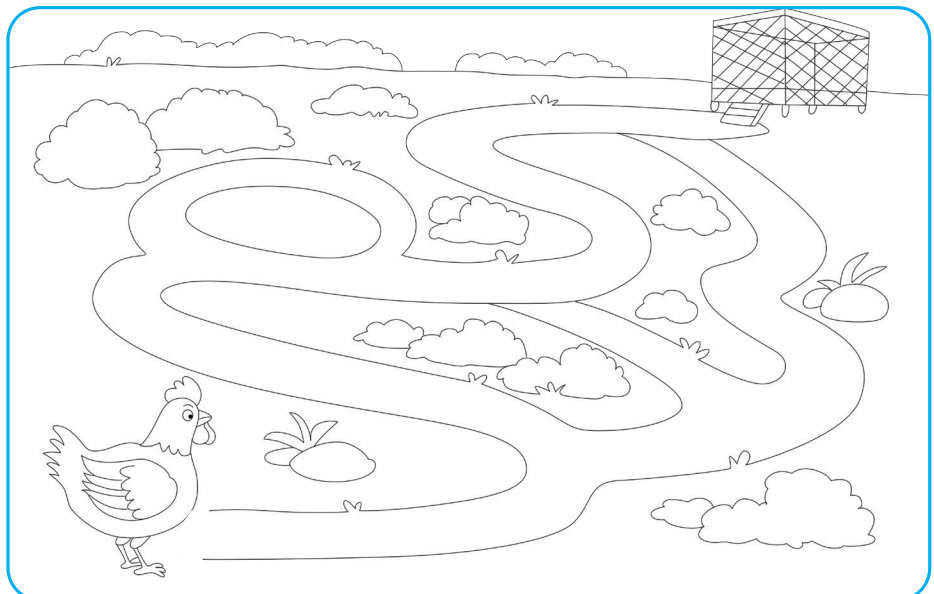



1. Look at the pictures and cross out (x) the incorrect words.



Library/Classroom



Classroom/Playground



Library/Computer room

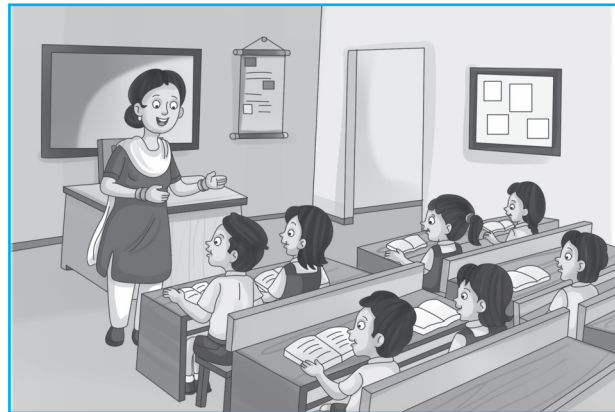

Classroom/Assembly hall

2. The letters in the names of some helpers at school have got jumbled up. Unscramble the letters and write the names correctly.

- TEECHAR : _____
- PRILCIPAN : _____
- POEN : _____
- GARNEDER : _____

3. In the word grid given below, find and mark five words related to a school.

F	S	D	P	K	N	R	S	K	W	N
R	V	C	L	A	S	S	R	O	O	M
D	T	E	A	C	H	E	R	L	M	P
T	P	F	Y	S	Q	D	M	V	K	W
K	U	S	G	D	R	F	K	D	C	X
L	I	B	R	A	R	Y	C	S	D	E
M	S	W	O	P	V	T	S	Q	G	R
P	U	V	U	D	M	S	B	P	J	S
R	M	U	N	I	F	O	R	M	K	P
Q	S	K	D	V	R	R	W	L	O	Q

4. Answer the following questions.

a. Which rooms or places do we see inside a school building?

b. What do we find in a school library?

c. What do the children do in the assembly hall?

d. What should we not do in the school?



1. Identify the places and write their names from the given box.

Market Bus stop Park Hospital

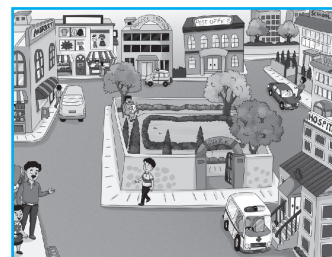
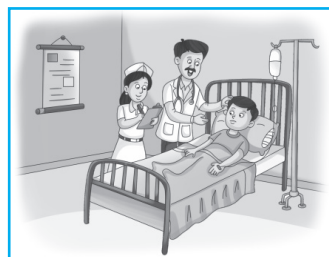

2. Match the pictures with the names of places.



Hospital

Bank

Post office

Park

3. Answer the following questions.

a. Why do we go to park?

b. Why do we go to the post office?

c. What should we not do to the public places?

4. Colour the picture.





1. Match the helpers with the statements.

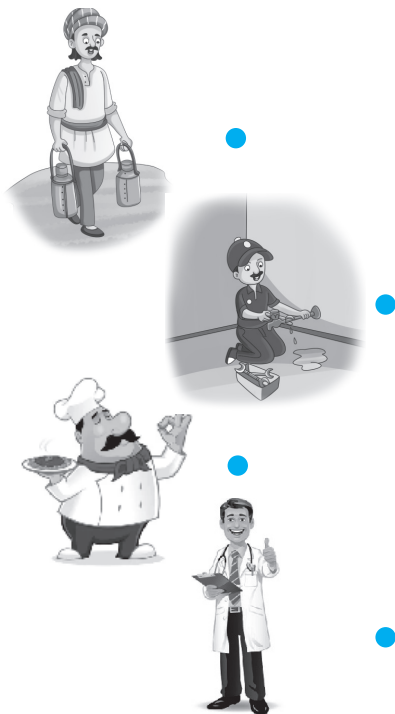

- "I treat you when you fall sick."
- "I bring milk for you."
- "I repair taps and pipes."
- "I cook food."

2. Tick (✓) the correct option.

- Where do doctors treat sick people?

a. At school <input type="checkbox"/>	b. At home <input type="checkbox"/>	c. In a hospital <input type="checkbox"/>
---------------------------------------	-------------------------------------	---
- Where do nurses do their work?

a. In a school <input type="checkbox"/>	b. In a hospital <input type="checkbox"/>	c. In a bank <input type="checkbox"/>
---	---	---------------------------------------
- Where do farmers grow crops?

a. In a park <input type="checkbox"/>	b. In a restaurant <input type="checkbox"/>	c. In a field <input type="checkbox"/>
---------------------------------------	---	--
- Where do teachers teach?

a. In a school <input type="checkbox"/>	b. In a bank <input type="checkbox"/>	c. In a hospital <input type="checkbox"/>
---	---------------------------------------	---
- Where does a chef cook food?

a. In a park <input type="checkbox"/>	b. In a restaurant <input type="checkbox"/>	c. In a bank <input type="checkbox"/>
---------------------------------------	---	---------------------------------------



1. Put a cross (×) under the odd picture.

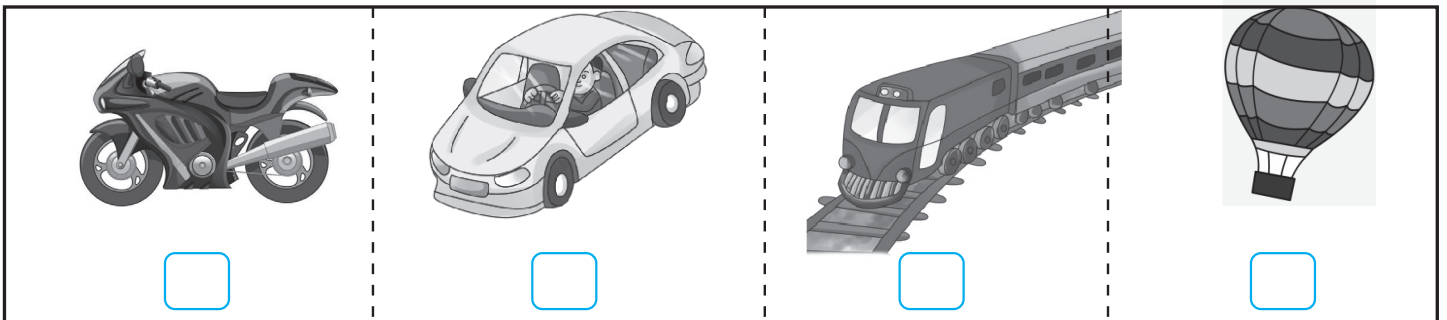
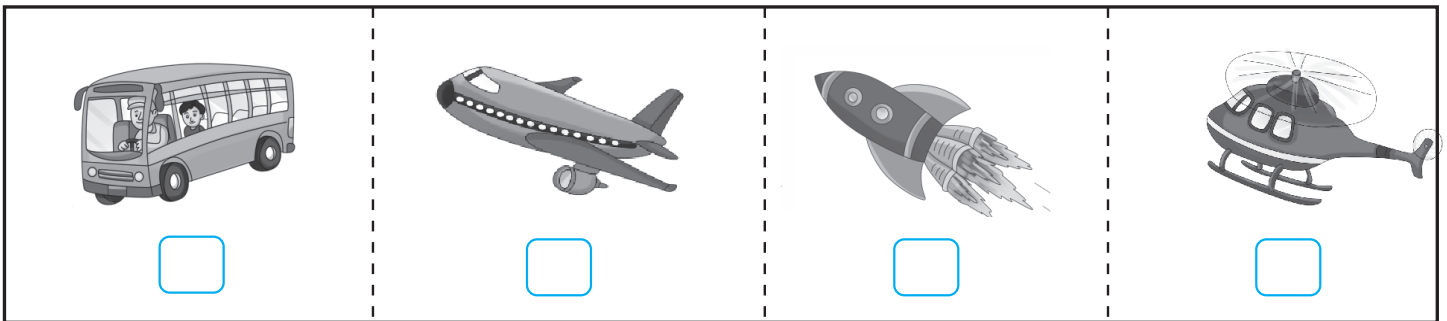
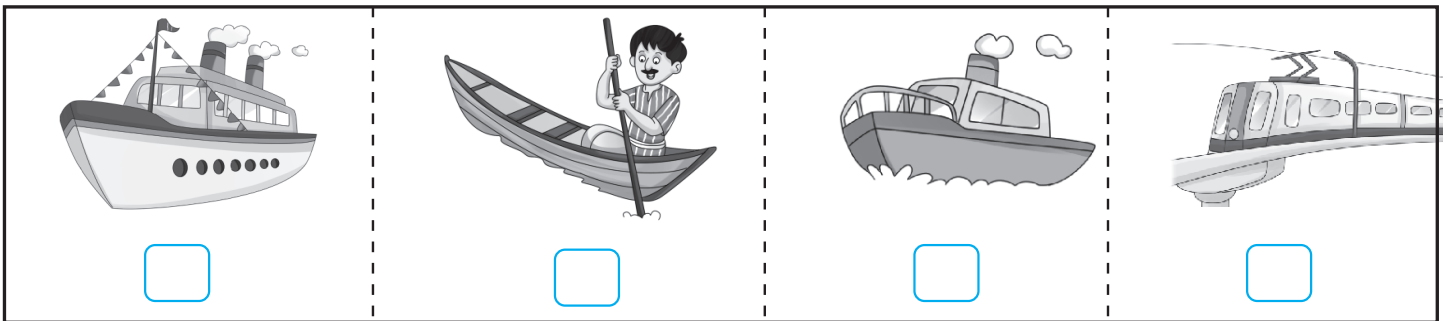

2. Circle the animals which are used to carry goods and people to different places.

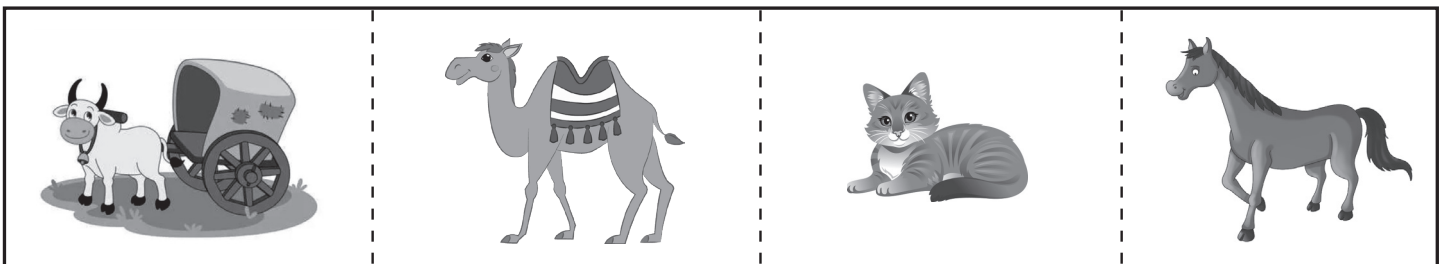

3. Answer the following questions.

a. Name the three types of transport.

b. What are called the means of water transport?

c. What are called the means of air transport?

d. How are animals used for transport?

4. Join the dots to complete the drawing of bus. Also, colour it.

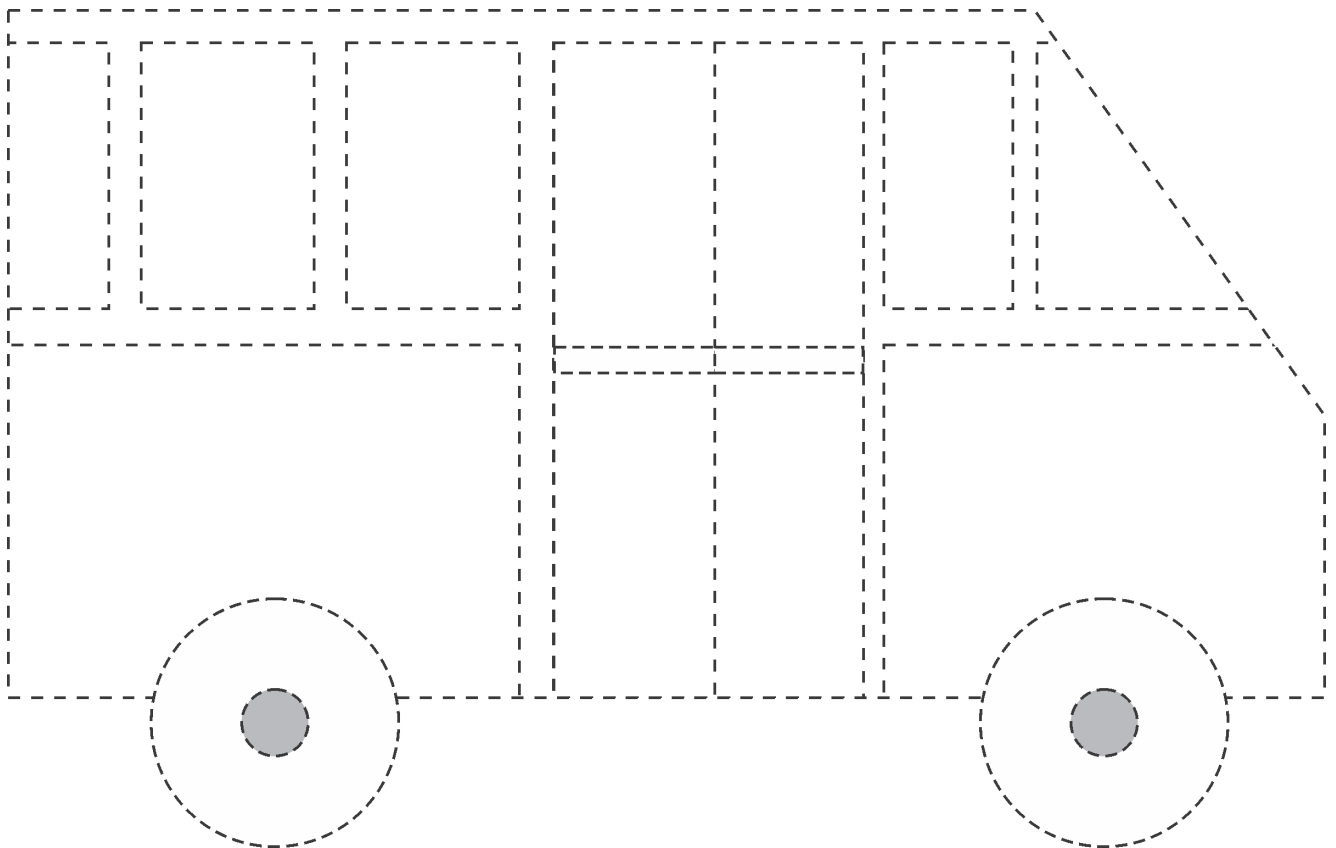



1. Write the names of Earth features from the given box.

Desert River Forest Hill Pond



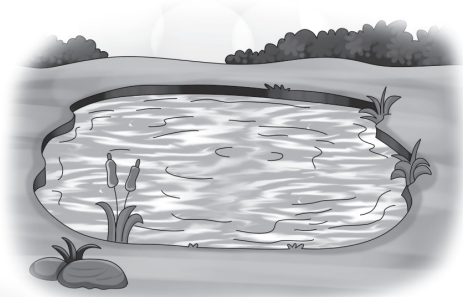

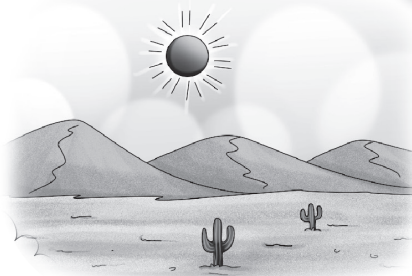

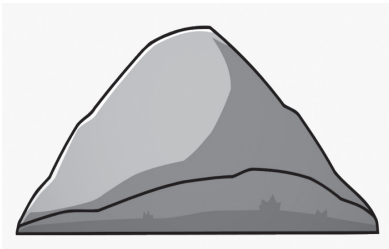



2. Answer the following questions.

a. For whom are air and water very important?

b. Where do we find water on Earth?

c. What does the moon seem to do every day?

3. Write E for an object that you see on the Earth. Write S for anything that you see in the sky.

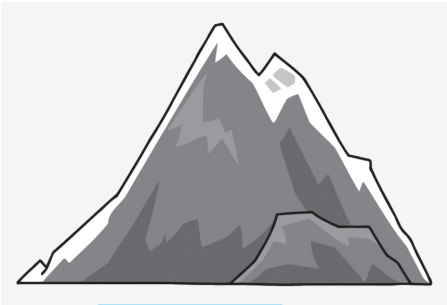

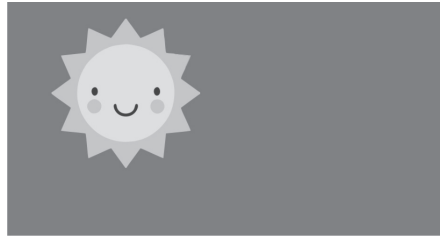

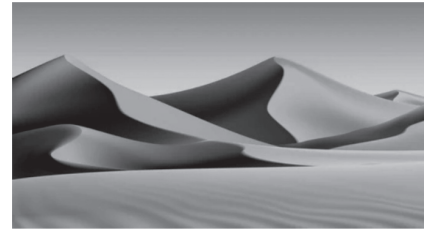

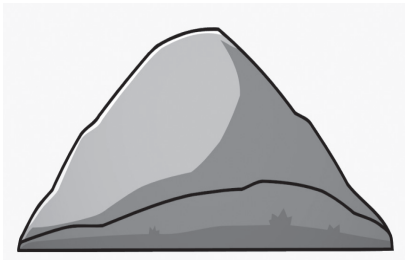



4. Find five differences between the following two pictures, marking them in the second one.

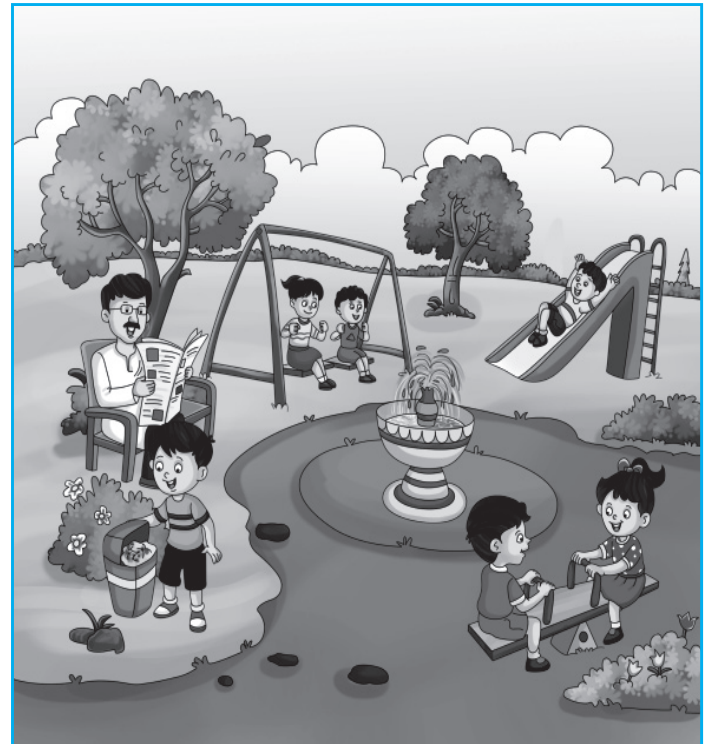
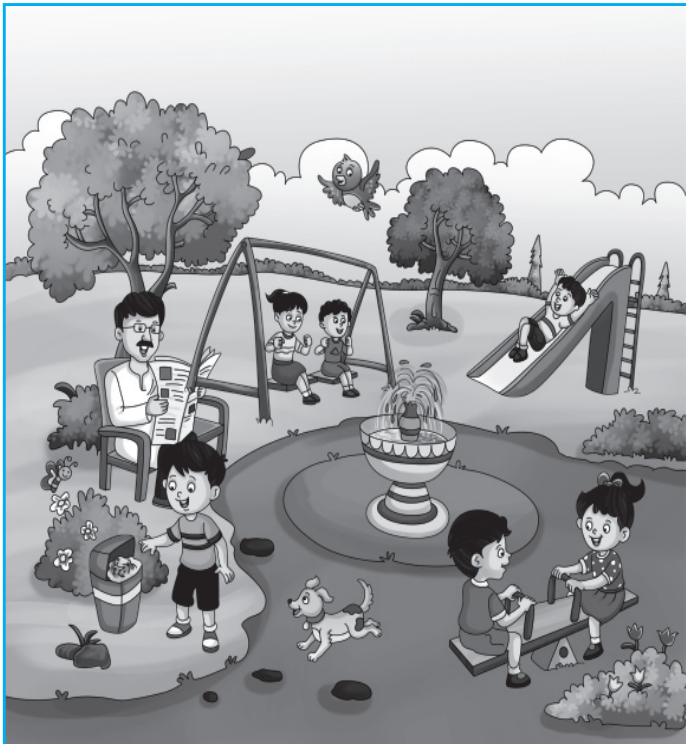



1. Match the festival names with the things associated with them.

Diwali



Eid



Christmas

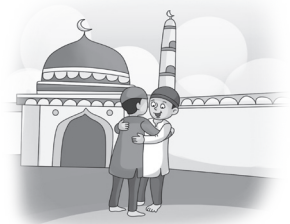

2. Answer the following questions.

a. When is the festival of Eid celebrated?

b. Write any two things that Sikhs do on Gurburab?

c. Who hoists the national flag at the Red Fort on Independence Day?

3. Tick (✓) the correct option.

• What do people exchange on festival days?

a. Sweets

b. Gifts

c. Both of these

• People worship Lord Ganesha and Goddess Lakshmi on this festival.

a. Diwali

b. Gurburab

c. Christmas

- Which national festival is celebrated on 15th August every year?
 a. Republic Day b. Independence Day c. Gandhi Jayanti
- Which national festival is celebrated on 26th January?
 a. Independence Day b. Gandhi Jayanti c. Republic Day
- Who is called the Father of the Nation?
 a. Mahatma Gandhi b. Rabindranath Tagore c. Neither of these

4. Trace from a to z to complete the Indian national flag. Also, colour it taking help from an elder.

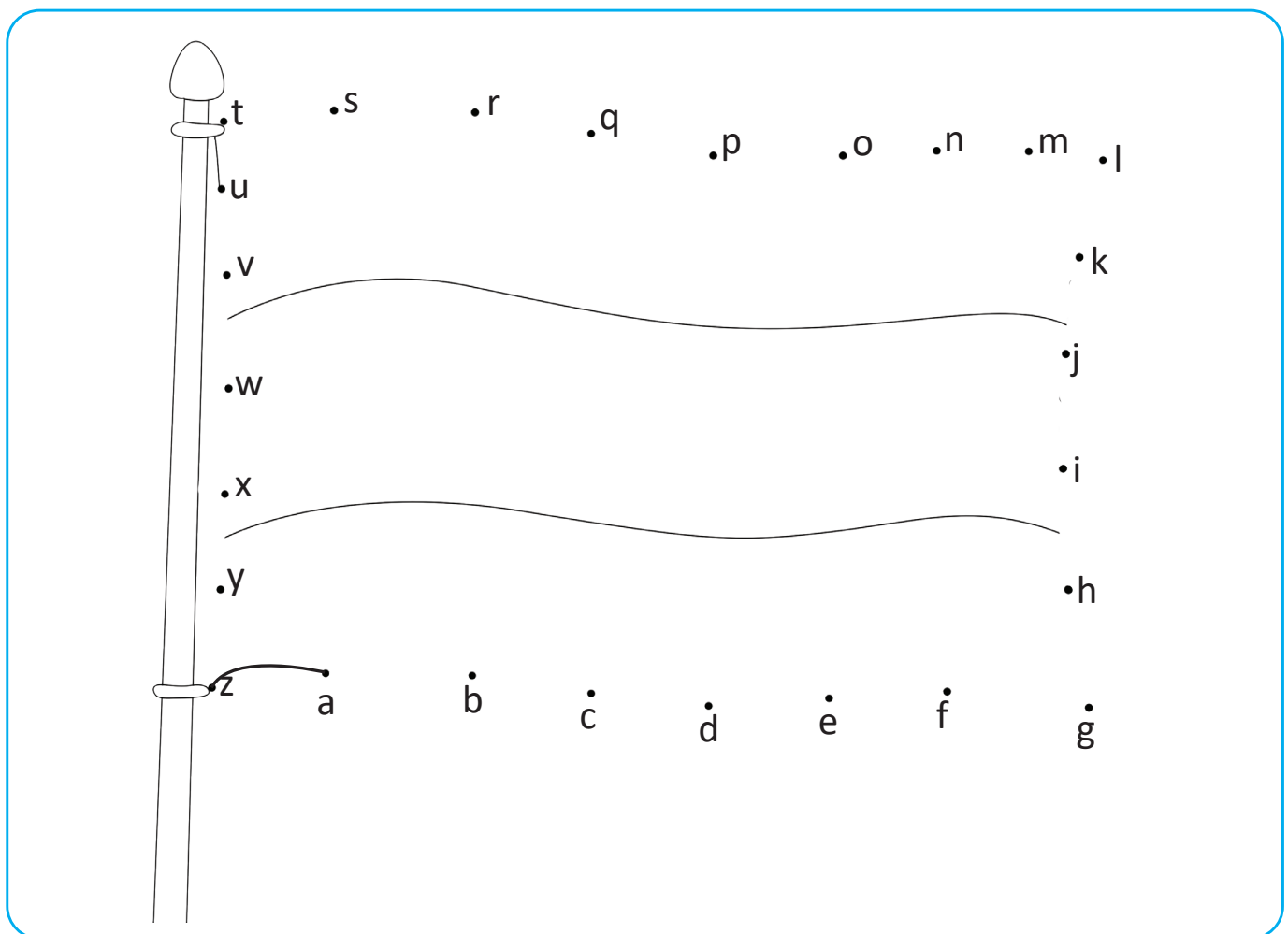



1. Cross out (×) the objects that you think are not safe for you to use.



2. Answer the following questions.

a. How can we avoid accidents?

b. Write any one safety tip while travelling by bus.

c. Write any two safety tips to be followed in the park.
